

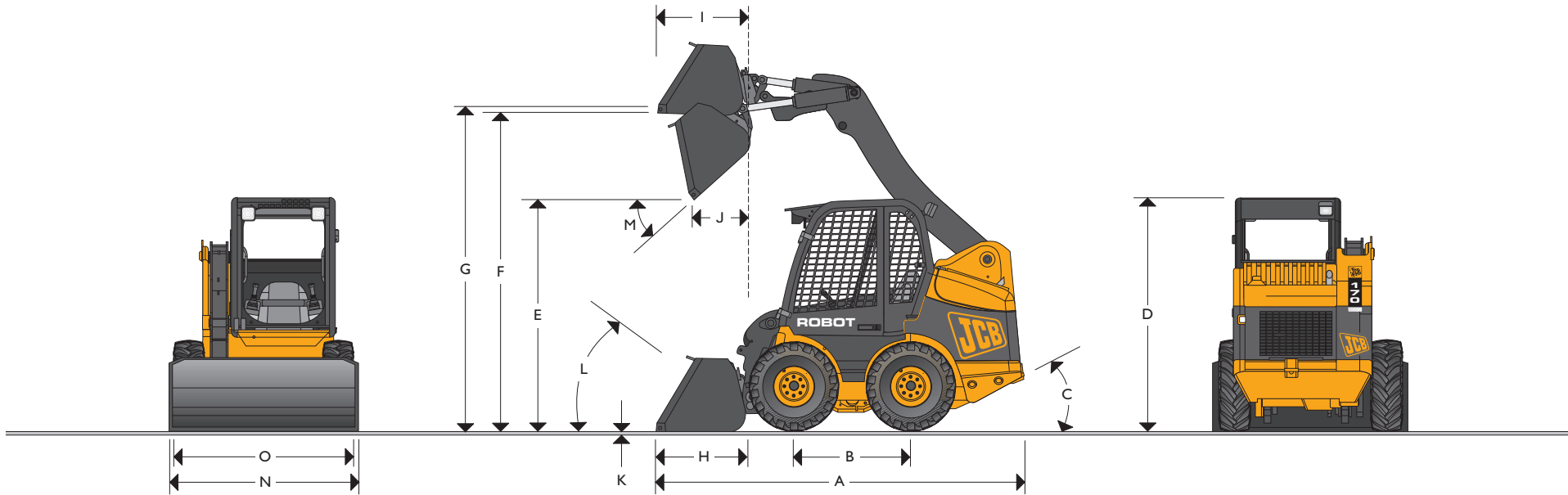

JCB ROBOT SKID STEERS | 160/170



OPERATING WEIGHT: 2410kg and 2510kg
 OPERATING CAPACITY: 600kg and 700kg



STATIC DIMENSIONS

	160	170
	m (ft-in)	m (ft-in)
A Overall length	3.21 (10-6.5)	3.27 (10-8.5)
B Wheel base	0.98 (3-2.5)	1.03 (3-4.5)
C Departure angles	degrees 28°	degrees 28°
D Overall height	1.93 (6-4)	1.94 (6-4.5)
E Dump height	2.16 (7-1)	2.29 (7-6)
F Loadover height	2.65 (8-8)	2.78 (9-1.25)
G Pin height	2.80 (9-2.25)	2.93 (9-7.25)
H Reach at ground (toe plate horizontal)	0.87 (2-10.25)	0.86 (2-9.25)
I Max reach at full height	0.86 (2-9.75)	0.76 (2-6)
J Reach at full height – fully dumped	0.57 (1-10)	0.47 (1-6.50)
K Dig depth (toe plate horizontal) clearance	0 (0-0)	0 (0-0)
L Rollback at ground	degrees 30°	degrees 30°
M Dump angle	degrees 40°	degrees 40°
N Shovel width – standard	1.43 (4-8)	1.58 (5-2)

	160	170
	m (ft-in)	m (ft-in)
Shovel width – optional	1.55 (5-1)	1.73 (5-8)
O Width over tyres – standard	1.37 (4-6)	1.60 (5-3)
Width over tyres – optional	1.52 (5-0)	1.52 (5-0)
Loader breakout – shovel	SAE tonnes 1.36	1.45
Lift capacity at full height	SAE kg (lb) 600 (1322)	700 (1543)
Maximum tipping load	SAE kg (lb) 1200 (2645)	1400 (3086)
Shovel capacity – standard	cu. m (cu. yd.) 0.29 (0.38)	0.36 (0.47)
Pallet fork rated capacity (50% safety factor at 400mm load centre) EN	495kg (1090lb)	555kg (1225lb)
Pallet fork lift height	2.70 (8-10)	2.83 (9-3.5)
Turning radius		
Bucket corner radius	1.87 (6-1.5)	1.97 (6-5.5)
Quick hitch radius	1.20 (3-11.25)	1.22 (4-0)
Rear chassis radius	1.58 (5-2)	1.62 (5-3.5)



JCB ROBOT SKID STEERS | I60/I70



MACHINE RATING

Rated operating capacity (SAE):	kg
I60	600
I70	700
Tipping load:	
I60	1200
I70	1400

ENGINE

4 cylinder: 404C-22, Engine conforms with EC mobile off-highway emissions regulations, Tier 2, 4 stroke, diesel engine. Indirect injection, naturally aspirated – 2.2 litres displacement. Water cooled.

		I60	I70
Gross power		@ 2600rpm	@ 2800rpm
SAE J1995	kW (hp)	35 (47)	37.5 (50)
NET power		@ 2600rpm	@ 2800rpm
SAE J1349 EEC 80/1269	kW (hp)	33 (44)	35 (47)
Gross torque @ 1800rpm			
SAE J1995	Nm (lb/ft)	143 (105)	143 (105)
NET torque @ 1800rpm			
SAE J1349 EEC 80/1269	Nm (lb/ft)	138 (102)	138 (102)

Exhaust smoke R24.03. Exhaust emissions 97/68/EC Stage 1. Engine oil service intervals: 500 hours. Fast start glow plugs.

TRANSMISSION

The full servo and optional manual controlled hydrostatic transmission giving zero to maximum speed, both forward and reverse at full power.

Independent transmission systems for both the left and right side, controlled through either servo or optional manual controls for precise and easy operation.

Travel speeds both forward and reverse:

I60	10 kph (6.25mph)
I70	11 kph (6.8mph)

CAPACITIES

I60 and I70	litres (gal)
Hydraulic system (inc. Tank)	30 (6.5)
Fuel tank	80 (17.6)
Chain Case	17 (3.7)
Engine coolant	8 (1.75)
Engine oil	9.6 (2.1)

CONTROLS

Three machine control format options. JCB full servo controls reduce lever efforts to a minimum and are logical and simple to use. Alternatively either manual hand or manual hand and foot controls well known and accepted by the skid steer buyer and operator. With all options the left hand control lever pivots rearwards as the operator restraint is raised, providing unparalleled machine entry and exit.

WEIGHT

SAE operating weight.

Fully operational with quickhitch, standard shovel, full fuel tank, fully glazed cab + 80kg operator:

I60	2410kg (5310lb)
I70	2510kg (5532lb)

TYRES

I60 Standard – 7.00 x 15 - 6 pr

I70 Standard – 10 x 16.5 - 6 pr Wide Track

Available Options – Standard Track
 Heavy Duty
 Wide Track
 Lifemaster
 31.5/13 x 16.5 Extra Floatation
 XZM
 XZSL
 JCB Airboss
 Solids

Floatation tyres are fitted for most applications. *For arduous conditions and hostile environments JCB Airboss tyres or solid tyres are recommended.

*For hard standing, heavy duties are recommended.



JCB ROBOT SKID STEERS | 160/170



HYDRAULICS

In addition to the main hydrostatic drive pumps, there is a dedicated loader and attachments supply pump (auxiliary hydraulics circuit optional on 160 and 170 models, standard on 170 HF).

Pump flow 160: 55 litres/minute
(12 gal/min) at 2600rpm engine speed.
Main relief pressure 185 bar (2683 psi).

Pump flow 170: 60 litres/minute
(13 gal/min) at 2800rpm engine speed.
Main relief pressure 185 bar (2683 psi).

- Low lever efforts give excellent and easy control of transmission loader and attachments.
- With manual hand and servo control formats the auxiliary hydraulics are foot pedal operated. With manual hand and foot controls the auxiliary hydraulic circuit is actuated via the right hand control lever. Both formats give progressive control of oil flow for precise attachment control.
- Hydraulic supply pipes run neatly on top of the loader arm under a protective guard for long life.
- Full flow, spin-on type hydraulic oil filter.
- Engine oil throughout for ease of servicing.
- The optional hi-flow circuit provides 115 litres/min (25 gal/min) pump flow to the front of the machine for operation of high capacity attachments such as cold planers.

LIGHTING AND ELECTRICS

12 volt, negative ground system.

95 Ah low maintenance battery.

55 amp alternator.

Roof console mounting of ignition, control switches, fuel gauge and hourmeter.

Also incorporated into the roof console the warning light cluster (with a warning buzzer to draw operator's attention to any malfunction) which includes:

- No charge pressure
- Blocked airfilter
- Engine water temperature
- Engine oil pressure
- Hydraulic oil pressure
- Alternator

Cab mounted fuse and relay box designed to keep dirt and water out.

OPERATOR ENVIRONMENT

Full ROPS and Level 1 FOPS with optional Level 2 guard for demolition. Soundproofing gives noise levels complying with EC regulations. Convenient and safe access through side door – thanks to JCB's unique single arm design.

- Unequaled all-round visibility.
- Fully adjustable seat.
- Seat belt fitted as standard.
- Drainage cover for easy cleaning of cab.

All in a bigger, more comfortable cab with a superior control layout.

STANDARD EQUIPMENT

ROPS and FOPS integrated canopy. Full audible and visual warning systems. Restraint activated safety system. Loader arm safety strut. Centrifugal dry type engine air filter with safety element. Self lubricating axle bearings. Standard shovel. Mechanical Quickhitch. Hand throttle. Worklights (EC only). Servo emergency lower valve. Fuel gauge. In-line diesel filter. Park brake.

OPTIONAL EQUIPMENT

Fully glazed cab with heater/demister. Air conditioning. Suspension seat. Road lights. Work lights (not EC). Reverse alarm. Beacon. Foot throttle (not with foot control format). Fire extinguisher. Toolkit. External mirror. Polyscreen kit. Roof screen (standard on cab). Self levelling lift. Float. Level 2 FOPS guard. Heavy Duty Rear door guard. Front screen guard. Auxiliary hydraulics. Bolt on lift points. Battery isolator. Accessory socket. Right-hand fender. Backhoe mounting brackets. Servo speed controller (standard on HF). Heavy duty pre-cleaner. Catalytic converter. Spark arrestor. Tooth guards. Twine cutters. Over tyre tracks. Engine block heater. Single lift point frame. Additional counterweights.



A GLOBAL COMMITMENT TO QUALITY

JCB's total commitment to its products and customers has helped it grow from a one-man business into Britain's largest privately owned manufacturer of backhoe loaders, crawler excavators, wheeled excavators, telescopic handlers, wheeled loaders, dump trucks, rough terrain fork lifts, industrial fork lifts, mini/midi excavators, skid steer loaders and tractors.

By making constant and massive investments in the latest production technology, the JCB factories have become some of the most advanced in Europe.

By leading the field in innovative research and design, extensive testing and stringent quality control, JCB machines have become renowned all over the world for performance, value and reliability.

And with a global sales and service network of over 400 distributors and agents, the company exports over 70% of its production to all five continents.

Through setting the standards by which others are judged, JCB has become one of Britain's most impressive success stories.

