

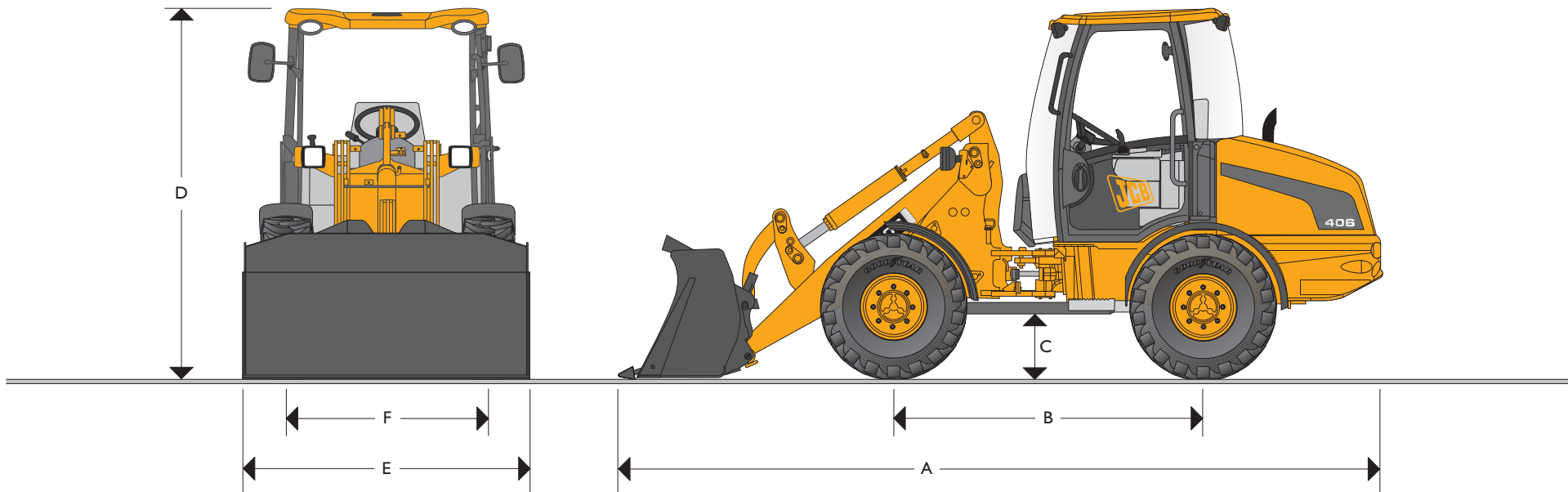

JCB WHEELED LOADING SHOVEL | 406



MAX. ENGINE POWER: 44kW (59hp)
 MAX. OPERATING WEIGHT: 5082kg (11204lb)
 MAX. LOADER CAPACITY: 0.8m³ (1.0yd³)



STATIC DIMENSIONS

	mm (ft-in)		kg (lb)	
A Overall length with standard shovel	5133 (16-10)	Front axle weight*	1434 (3161)	
B Wheel base	2100 (6-11)	Rear axle weight*	3500 (7716)	
C Min. ground clearance	330 (1-1)	Operating weight (includes standard shovel)	4934 (10877)	
D Height over cab	2500 (8-2)	Inside radius	2010 (7-7)	
E Max. shovel width	1900 (6-3)	Maximum radius over standard shovel	4160 (15-8)	
F Wheel track	1390 (4-7)	Maximum radius over tyres	3800 (12-6)	
		Articulation angle	± 40°	
		Max. width across tyres	1761 (6-9)	

Note: Dimensions assume fitment of standard JCB 12.5x18 wheel and tyres. *Axle weights based on unloaded bucket in carry position.



JCB WHEELED LOADING SHOVEL | 406



ENGINE

Type	4 cylinder diesel	
Make	Deutz	
Model	F4L2011	
Capacity	ltr (in ³)	3.11 (189.7)
Bore	mm (in)	94 (37)
Stroke	mm (in)	112 (44)
Aspiration	Naturally aspirated	
Cylinders	4	
Power rating		
Gross power to SAE J1995/ISO 14396	kW (HP) @ 2500rpm	44 (59)
Nett power to J1349/EEC 80/1269	kW (HP) @ 2500rpm	41.5 (56)
Torque rating		
Gross torque	Nm (lbf ft) @ 1700rpm	190 (140)

TRANSMISSION

Type	Hydrostatic	
Make	Rexroth	
Model	A6VM	
Low range	kph (mph)	6 (3.8)
High range	kph (mph)	20 (12.4)

AXLES

Type	Straight beam	
Make	JCB	
Model	111	
Overall axle ratio / Drop box ratio	19.33 / 2.23	
Chassis angle oscillation	degrees	± 10°

LOADER HYDRAULICS

Pump type	Gear	
Pump max. flow	l/min (UK gal/min)	60 (10.3)
Pump max. pressure	bar (lb/in ²)	230 (50.6)
Hydraulic cycle times at full engine revs:		
Arms raise (full bucket)	seconds	
Bucket dump (full bucket)	4.9	
Arms lower (empty bucket)	3.5	
Arms lower (empty bucket)	3.1	
Total cycle	11.5	

SERVICE FILL CAPACITIES

	litres (UK gal)
Hydraulic and transmission system	70 (15.4)
Fuel tank	80 (17.6)
Engine oil sump	12 (2.6)
Axle oil (front)	3.9 (0.9)
Axle oil (rear)	3.9 (0.9)

ELECTRICAL SYSTEM

System voltage	Volt	12
Alternator output	Amp hour	80
Battery capacity	Amp hour	115

STANDARD EQUIPMENT

Loader: Single lever joystick control; Parallel lift geometry; Quickhitch (hydraulic pin locking).

Engine: 4 cylinder oil cooled diesel engine; dual stage cyclonic engine air filter; Single bowl fuel filter; Fan guards.

Transmission: Two position electric switch; Neutral start; Disconnect on footbrake (inching capability); Forward/reverse switch on joystick control lever.

Axles: Straight beam axles.

Brakes: In board oil immersed brakes with combined handbrake.

Electrical: Road lights front and rear; Reverse lights; 80 Amp alternator.

Hydraulics: Gear pump with priority steer; Emergency steer back up; 3 spool loader circuit.

Cab: ROPS/FOPS safety structure; Fully adjustable seat; Interior light; Adjustable steering column; Safety glass; Electronic monitoring with warning panel; Front and rear screen wash/wipe; 3 speed heater fan with replaceable filters; Optional analogue gauges; LH opening door; Up and over handbrake with catch; Radio aperture (high spec cab only); Single lever joystick control; Laminated screen; Loader control isolator; Door lock back system; Storage tray.

Bodywork: Front and rear fenders; Side and rear access panels; Fixed bottom steps; Full width rear counterweight; Recovery hitch; Lifting lugs; Engine sump kit, 12.5 R18 JCB tyres.

OPTIONAL EQUIPMENT

Limited slip differential axles front/rear; 3 HBCV; Epoxy coated cooling pack; Smooth ride system; Air suspension seat; Creep speed; 4th spool auxiliary circuit; High spec cab; Front and rear working lights; Fire extinguisher; Face level fan; Radio installation kit; Reverse alarm; Rotating beacon; Adjustable steering column; Reversing lights and rear fog lights; Sun visor; Biodegradable oil; Sliding window; 407/409 adapter plate.

TYRES

12.5/80 R18 SGL, 335/80 R18 XM27, 12.5 R18 SLR4, 335/80 R18 XZSL, 335/80 R18 SPT9, 365/70 R18 SPT9, 405/70 R18 SPT9, 400/70 R18 IT520.

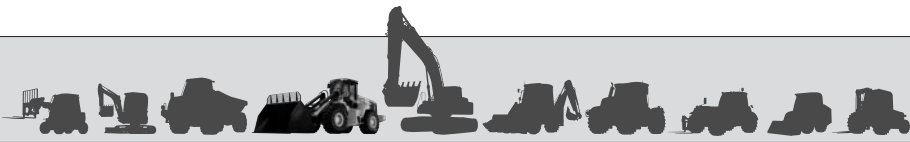

LOADER DIMENSIONS

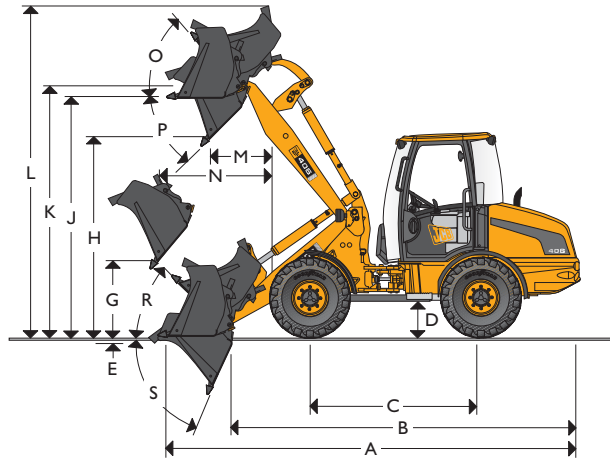

LOADER DIMENSIONS

Shovel		General Purpose	General Purpose	Light Duty	Light Duty	6 in 1 Clam Shovel
Capacity heaped	m ³ (yd ³)	0.8 (1.0)	1.0 (1.3)	1.2 (1.6)	1.4 (1.8)	0.75 (1.0)
Material density	kg/m ³ (lb/yd ³)	2050 (3400)	1620 (2688)	1320 (2190)	1120 (1858)	2100 (3484)
Empty shovel weight	kg (lb)	287 (633)	322 (710)	353 (778)	384 (846)	435 (959)
Bucket equipment		Teeth or Toeplate	Teeth or Toeplate	Teeth or Toeplate	Teeth or Toeplate	Teeth or Toeplate
Static tipping load, straight (EN)	kg (lb)	4290 (9458)	4212 (9268)	4118 (9079)	4076 (8986)	4095 (9028)
Static tipping load, full turn 40° (ISO)	kg (lb)	3300 (7275)	3240 (7143)	3168 (6984)	3136 (6914)	3150 (6945)
Payload 50%	kg (lb)	1650 (3638)	1620 (3571)	1584 (3492)	1568 (3456)	1575 (3472)
Max. tearout force	kN	41.9	36.5	32.2	29.7	41.9
Bucket width	mm (ft-in)	1900 (6-3)	1900 (6-3)	1900 (6-3)	1900 (6-3)	1900 (6-3)
Outside turning circle radius	mm (ft-in)	4160 (13-8)	4185 (13-9)	4210 (13-10)	4229 (13-10)	4160 (13-8)
A Total length (shovel flat on ground)	mm (ft-in)	5133 (16-10)	5233 (17-2)	5333 (17-9)	5408 (18-9)	5133 (16-10)
L Lift height max.	mm (ft-in)	4140 (13-7)	4246 (13-1)	4333 (14-6)	4438 (14-7)	4157 (13-8)
E Digging depth	mm (ft-in)	105 (0-4)	105 (0-4)	105 (0-4)	105 (0-4)	105 (0-4)
H Dump height	mm (ft-in)	2489 (8-2)	2418 (7-11)	2348 (7-8)	2295 (7-6)	2489 (8-2)
M Reach at max height @ 45° dump	mm (ft-in)	764 (2-6)	835 (2-9)	905 (3-0)	958.5 (3-2)	764 (2-6)
N Max. reach @ 45° dump	mm (ft-in)	1494 (4-11)	1465 (4-10)	1635 (5-2)	1689 (5-6)	1494 (4-11)
Operating weight	kg (lb)	4934 (10870)	4969 (10950)	5000 (11020)	5031 (11090)	5082 (11200)

PALLET FORK DIMENSIONS

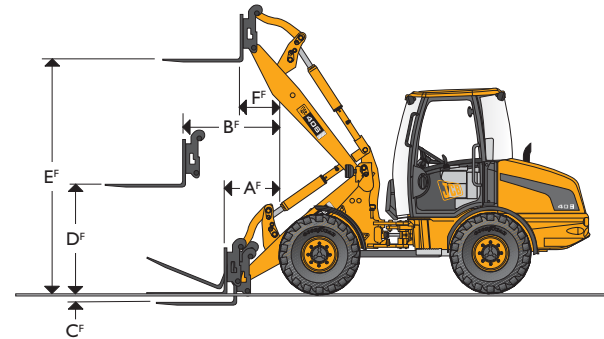

PALLET FORK DIMENSIONS

Loader dimensions: assumes fitment of 12.5x18 tyres.

		mm (ft-in)
Fork carriage width		1345 (4-5)
Length of tines		1200 (3-11)
A^F Reach at ground level		710 (2-4)
B^F Max. reach arms horizontal		1232 (4-1)
C^F Below ground level		84 (0-3)
D^F Height arms horizontal		1426 (4-8)
E^F Max. height		3012 (9-11)
F^F Reach at max. height		506 (1-8)
Full turn tipping load (500mm load centres)	kg (lb)	2580 (5688)
Operating load (60%)	kg (lb)	1548 (3412)
Operating load (80%)	kg (lb)	2064 (4409)

LOADER DIMENSIONS

		mm (ft-in)
B		4369 (14-4)
C		2100 (6-11)
D		330 (1-1)
F		2500 (8-2)
G		906 (8-0)
J		2991 (8-10)
K		3131 (10-3)
O	degrees	56°
P	degrees	45°
R @ carry	degrees	54°
S	degrees	67°



A GLOBAL COMMITMENT TO QUALITY

JCB's total commitment to its products and customers has helped it grow from a one-man business into Britain's largest privately owned manufacturer of backhoe loaders, crawler excavators, wheeled excavators, telescopic handlers, wheeled loaders, dump trucks, rough terrain fork lifts, industrial fork lifts, mini/midi excavators, skid steer loaders and tractors.

By making constant and massive investments in the latest production technology, the JCB factories have become some of the most advanced in Europe.

By leading the field in innovative research and design, extensive testing and stringent quality control, JCB machines have become renowned all over the world for performance, value and reliability.

And with a global sales and service network of over 400 distributors and agents, the company exports over 70% of its production to all five continents.

Through setting the standards by which others are judged, JCB has become one of Britain's most impressive success stories.

