



# JCB ROUGH TERRAIN FORK LIFT | 926/930



OPERATING WEIGHTS:

5910 to 6340 kg (13029 to 13977lb)

LIFT CAPACITY:

2.6 to 3.0 tonnes (5732 to 6613lb)

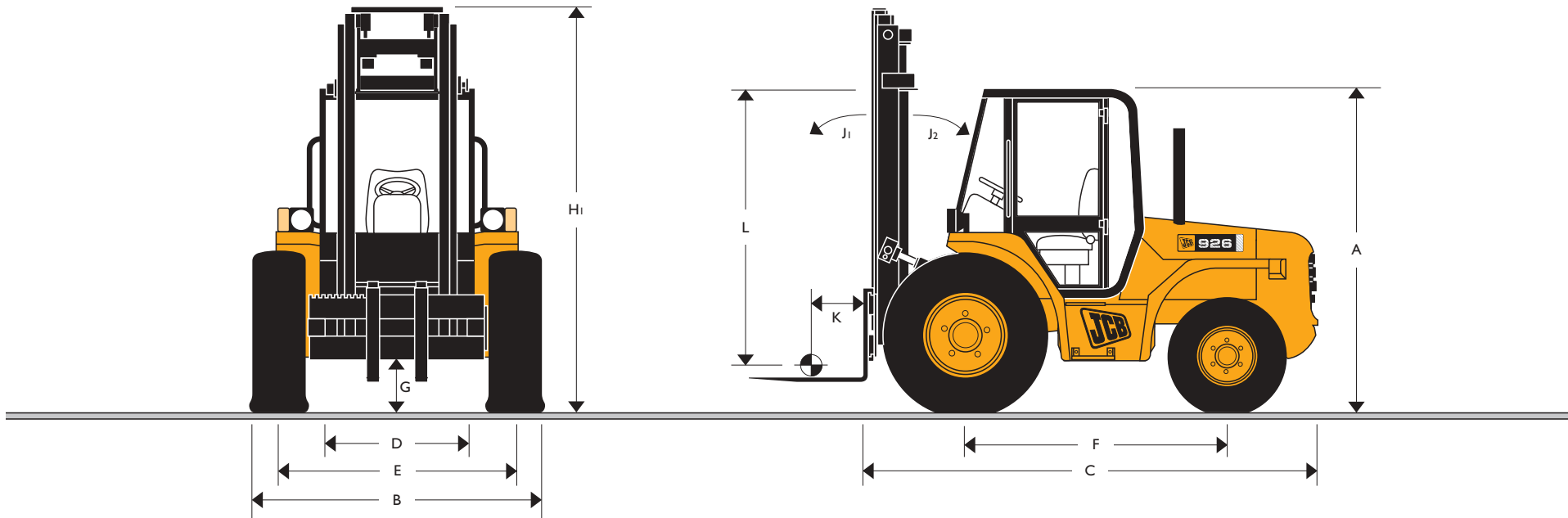

## DIMENSIONS

Machine model	926 m (ft-in)	930 m (ft-in)
A Overall cab height	2.57 (8-5)	2.57 (8-5)
B Overall width (over tyres)	2.20 (7-2½)	2.20 (7-2½)
C Overall length to front carriage (industrial or bar)	3.60 (11-10)	3.60 (11-10)
D Inside width of cab	1.16 (3-9½)	1.16 (3-9½)
E Front track	1.80 (5-11)	1.80 (5-11)
F Wheel base	2.13 (7-0)	2.13 (7-0)
G Ground clearance	0.37 (1-2½)	0.37 (1-2½)
Hi Mast closed height		
3.6m mast	2.95 (9-8)	2.95 (9-8)
4.5m mast	2.41 (7-10)	2.41 (7-10)

Machine model	926	930
5.5m mast	2.95 (9-8)	2.95 (9-8)
6.55m mast	3.32 (10-11)	3.32 (10-11)
H2 Mast open height		
3.6m mast	4.78 (15-8)	4.78 (15-8)
4.5m mast	5.41 (17-9)	5.41 (17-9)
5.5m mast	6.61 (21-8)	6.61 (21-8)
6.55m mast	7.67 (25-2)	7.67 (25-2)
J1 Mast tilt forwards	18°	18°
J2 Mast tilt backwards	10°	10°
K Load centre	0.50 (1-8)	0.50 (1-8)
L Free lift (4.5m mast only)	1.46 (4-9½)	1.46 (4-9½)

The above data based on the following specification: Standard fork size 1067 x 100 x 50 mm (42 x 4 x 2 in)



# JCB ROUGH TERRAIN FORK LIFT | 926/930



## TURN RADIUS & GROUND LINE ANGLES

Machine model	926	930
	m (ft-in)	m (ft-in)
Outside turn radius	4.49 (14-8 <sup>3</sup> / <sub>4</sub> )	4.49 (14-8 <sup>3</sup> / <sub>4</sub> )
Departure angle	53°	43°
Obstruction angle	51°	51°

The above data based on the following specification: Standard fork size 1067 x 100 x 50 mm (42 x 4 x 2 in)

## WEIGHT

Machine model	926	930
	kg (lb)	kg (lb)
Overall weight	5910 (13025)	6340 (13973)

The above data based on the following specification: Standard fork size 1067 x 100 x 50 mm (42 x 4 x 2 in)

## ENGINE

Naturally aspirated 55.9kW (76hp) at 2200rpm; 4 cylinders: bore 103mm (4.05in); stroke 127mm (5in); displacement 4.232 litres (258in<sup>3</sup>). Latest technology and advanced design provides low fuel consumption, reduced noise, high torque and power output, total reliability and minimal maintenance. Easily replaceable pre-finished dry liners. 5 bearing, heat treated crankshaft. Expansion controlled pistons. Two stage dry type air filter with primary and safety elements and optional glass bowl pre-cleaner.

## TRANSMISSION

For unbeatable drive power in all conditions, the JCB Syncro Shuttle combines a 4-speed, fully synchromesh gearbox with integral torque converter and electrically operated reversing shuttle for smooth gear changes on the move and fast cycle times. Column mounted electric switch effortlessly controls machine direction changes allowing operator to keep hands on steering wheel. Automotive style pedal layout and conventional H-pattern gear lever add to ease of operation. Travel speed 29.0km/h (18mph).

**Front drive axle:** JCB epicycle hub reduction drive axle with Max-Trac torque proportioning differentials.

**Rear steer axles:** JCB manufacture with hydrostatic power steering. Steer shock valve as standard. 4WD versions with epicyclic hub reduction and Max-Trac torque proportioning differentials. 2WD versions have a deadsteer axle as standard.

## BRAKES

**Service brakes:** Hydraulically activated, self-adjusting, oil-immersed in-board multi-disc type in front axle.

**Parking brake:** Hand operated disc brake on output of gearbox.

## MASTS AND CARRIAGES

Clearview masts manufactured from channel and I-section steel. Heavy duty mast chains. Guide roller bearings are sealed for life. Industrial class IIIB carriage, or bar carriage available for all masts. All carriages have side thrust rollers. Adjustable right hand tilt ram.

## TYRES

Machine model	926		930
	m (ft-in)		m (ft-in)
Standard tyres	16.5/85-24		16.5/85-24
(UK) Front	Traction		Traction
Rear 2WD	12.5/80-18		12.5/80-18
	Rib and bar		Rib and bar
Rear 4WD	12.5/80-18	10.5-18	12.5/80-18
	Traction	Traction	Traction

## HYDRAULICS

Single gear pump with steer priority valve, suction strainer and filter. Operating system pressure: 221 bar (3200psi), flow 55 ltr/min (12.5gal/min). Pipe burst protection on mast hydraulics.

## AUTOMATIC DERATION

Deration valve: 5.5m and 6.70m masts are fitted with a deration valve which automatically reduces lift capacity above 4.5m for safety and stability.

## SERVICE CAPACITIES

	litres (UK gal)
Fuel tank	88 (19.0)
Hydraulic tank	60 (13)
Coolant	17 (3.7)

## ELECTRICS

12v negative earth. 95Ah battery. 65 amp alternator. Full road lighting, direction indicators, hazard warning reverse and fog light.

## OPERATOR MODULE

Safety quiet cab or canopy, FOPS standard (falling object protective structure) to FEM Section IV and ANSI B56.6 – 1978.

**Cab:** resiliently mounted, two door access, level floor with mat, safety glass all round with laminated roof window, bolt on roof bars. Fitments include: velour seat, rear view mirror and 2 speed heater/demister. Front/Rear screen wiper and washer, horn. Handbook. Instruments for hourmeter battery charge. Audible/Visual warning system for alternator charge, coolant temperature, engine oil pressure, blocked air filter, transmission oil pressure and temperature. Warning lights for: main beam, hazard warning, park brake on, direction indicators. Hydraulic control levers, gear lever, park brake, forward/reverse lever, 4WD disconnect, throttle, brake, and transmission disconnect pedal.

**Canopy:** as above but with no glazing (screen wiper and heater/screen demister not applicable), and rear fenders are standard.

## OPTIONS AND ATTACHMENTS

Auxiliary carriage services via hose reel for powered attachments. Wheel and tyres sets. Tinted cab glazing. Suspension seat. Seat belt. Roof screen wash/wipe. Flashing roof beacon. Fire extinguisher. Cab exterior mirrors. Front screen bars. Optional rear fenders. Reversing lights. Reverse alarm. Electrical fuel level gauge. Propshaft guards. Chaff guard. Air pre-cleaner. Engine fan guard kit. Hose guard kits. Load guard. Contact your local dealer for details of the comprehensive range of attachments.



# JCB ROUGH TERRAIN FORK LIFT | 926/930



## 926 CAPABILITIES

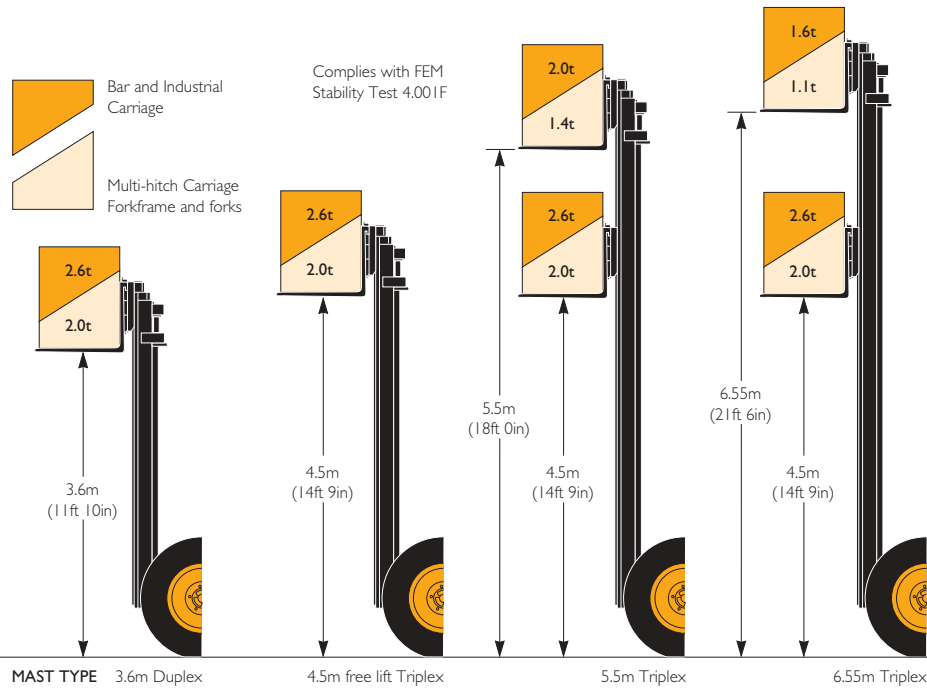

## 930 CAPABILITIES

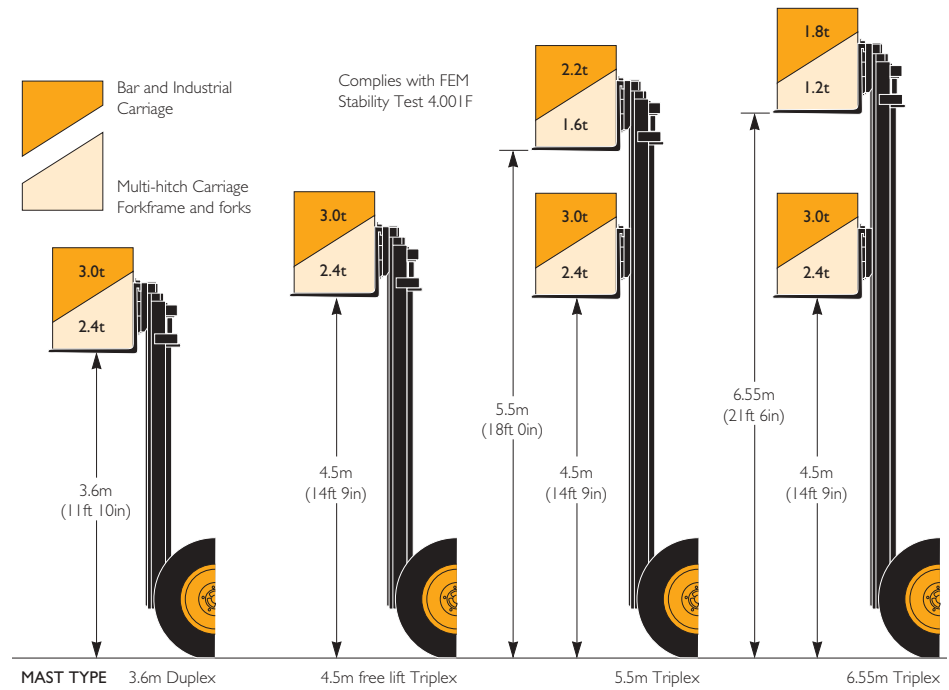



## A GLOBAL COMMITMENT TO QUALITY

JCB's total commitment to its products and customers has helped it grow from a one-man business into Britain's largest privately owned manufacturer of backhoe loaders, crawler excavators, wheeled excavators, telescopic handlers, wheeled loaders, dump trucks, rough terrain fork lifts, industrial fork lifts, mini/midi excavators, skid steer loaders and tractors.

By making constant and massive investments in the latest production technology, the JCB factories have become some of the most advanced in Europe.

By leading the field in innovative research and design, extensive testing and stringent quality control, JCB machines have become renowned all over the world for performance, value and reliability.

And with a global sales and service network of over 400 distributors and agents, the company exports over 70% of its production to all five continents.

Through setting the standards by which others are judged, JCB has become one of Britain's most impressive success stories.

